

TIME-SERT®

GLOW PLUG REPAIR KIT 2 STYLE REPAIR M10x1.25 DURAMAX 6.6 DIESEL p/n 5000

Early version: Glow plug thread starts approx 1/4" or 6mm below hex of plug.
2001 – 2004.5 6.6L Duramax

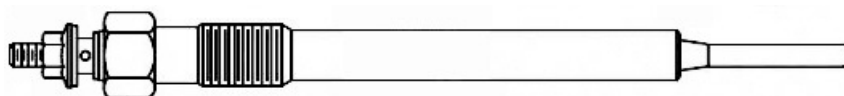

Later version: Glow plug thread starts approx 1.00" or 25mm below hex of plug.
2006 – 2010 6.6L Duramax

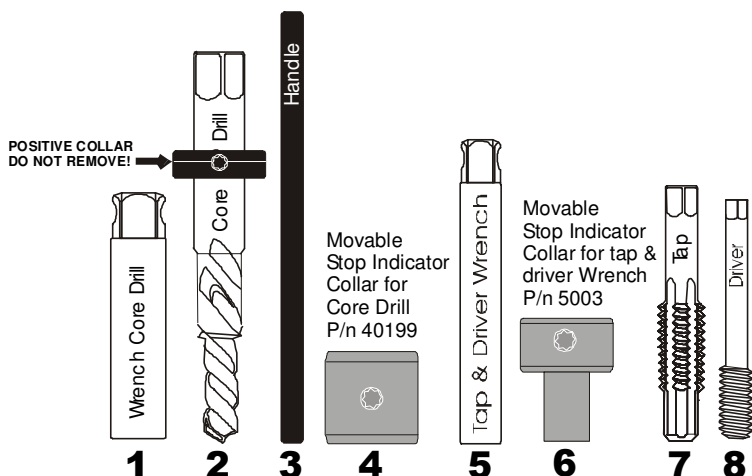
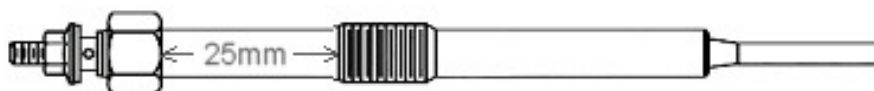

PART NUMBER KIT 5000

KIT CONTENTS

1. Wrench for Core Drill
2. Core Drill
3. Handle
4. Movable Stop indicator Collar for Core drill
5. Wrench for Tap & Driver
6. Movable Stop indicator Collar for tap & driver Wrench
7. Pilot Tap
8. Driver tool
9. Aluminum inserts (5)
P/n 10123ANF no flange

Use WD40 for drilling & tapping

-WARNING-

Cutting tools may shatter if broken. The wearing of safety glasses is required in the vicinity of their use.

(Preparing hole) Before we begin, tape the straw provided or a piece of hose long enough to reach the bottom of hole, and use a shop vac for chip removable.

Using a small quarter size piece of tissue, roll up into a ball and drop down glow plug hole. This will help prevent chips from going into the chamber. The tissue will later be vacuumed out after drilling and tapping.

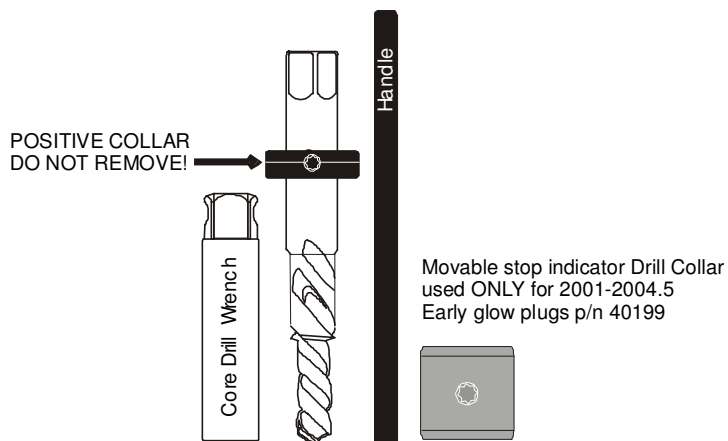

1. Place the core drill into the large wrench p/n 40192G1 and tighten the set screw. Place handle in wrench to turn drill. Use WD40 on the Core drill for drilling.

Only use the movable stop indicator collar p/n 40199 for 2001 – 2004.5 Early Version heads.

Turn page over to continue

Early version
2001-2004.5

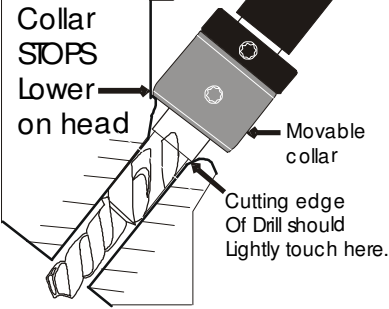

Later version
2005-2010

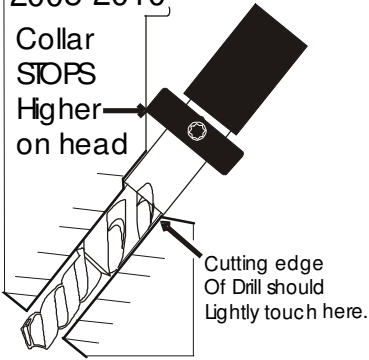

Continued from Step 1
Drill close-up:

Core drill the hole until the Stop Collar touches the head and spins freely. Do not use excessive force. The stop collar is just a Stop indicator to notify you the cutting edge is in contact with the head.

Vacuum chips from hole.

Use another small quarter size piece of tissue, roll up into a ball and drop down glow plug hole to prevent chips from entering chamber.

Early version
2001-2004.5

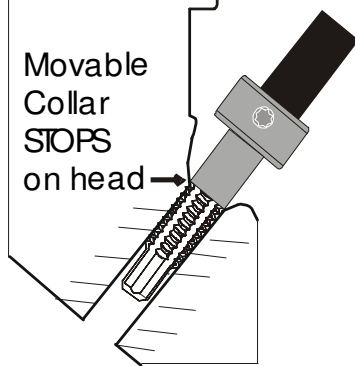

Later version
2005-2010

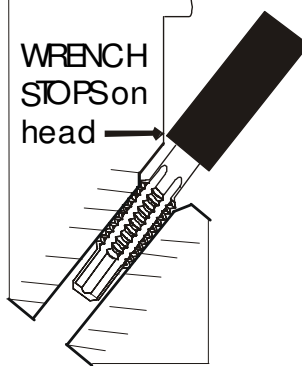

2. Note: If vehicle is 2001-2004.5 Early version style glow plug. Use movable stop collar p/n 5003 on tap Wrench. Late version DO NOT.

Place the tap into the small wrench p/n 5002 and tighten setscrew. Place handle in wrench to turn tap. Use WD40 on tap for tapping.

Tap until "Stop collar" or "Wrench" stops on the head. Do not use excessive force.

The "collar for 2001-2004.5" or "Wrench for 2005-2010" is just a Stop indicator to notify you that the hole is tapped deep enough to accept the insert.

Vacuum chips as needed. Use brake cleaner to clean out oil residue after tapping.

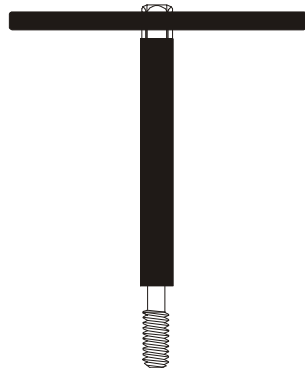

Oil the bottom threads of the install driver

DRIVER TOOL:

REMOVE THE COLLAR FROM WRENCH IF ONE EXISTS. WE DO NOT USE THE MOVABLE INDICATOR COLLAR FOR DRIVER INSTALL FOR ANY YEAR.

3. Place the install driver into the wrench, tighten setscrew.

Oil the bottom threads of the install driver.

Use Time-Sert install driver oil p/n 6010 or 30wt motor oil.

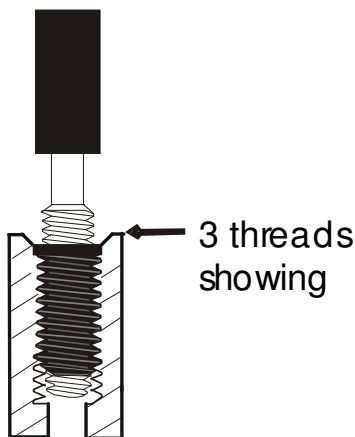

STOP WHEN 3 threads are showing do not go deeper.

4. Screw the insert onto the driver a few turns and into the prepared hole. While screwing the insert into the hole the driver will tighten up, continue screwing the driver thru the insert and **STOP WHEN 3 threads are showing**. Do not go any deeper or you can break the driver in the hole.

**Back driver tool out of insert.
Repair Complete.**

Use copper anti-seize on the threads of the glow plug and use the correct torque specs when installing new glow plug.

